

Elmdene International Ltd
3 Keel Close, Interchange Park
Portsmouth, Hampshire, PO3 5QD, UK

Tel: +44 (0)23 9269 6638
Fax: +44 (0)23 9266 0483
Web: www.elmdene.co.uk

Universal PSU Range

Models : UNIVERSAL-12V-5A-M
UNIVERSAL-12V-5A-L
UNIVERSAL-24V-3A-M
UNIVERSAL-1224-L

INTRODUCTION

This manual covers a range of Power Supplies and enclosures designed for use in Access Control and General Security applications. Each version comprises a 13.8Vdc or 27.6Vdc high efficiency, switched mode Power Supply designed to fit into a robust metal enclosure. It has a unique universal mounting system to allow fitment of a variety of 3rd party controllers or electronic devices. The Power Supplies provide continuous full rated current to load plus an additional 0.5A battery charging for standby lead acid batteries. Normal operation and fault signal outputs are provided.

FEATURES

- Continuous full rated current to load.
- Universal mains input rated voltage ranging from 100Vac to 240Vac.
- 12Vdc, 24Vdc and selectable 12Vdc / 24Vdc options.
- High efficiency electronics for reduced running costs and lower operating temperatures.
- Installer safe design with all high voltage electronics fully protected.
- Full electronic short circuit and overload protection on load output under mains operation.
- Mains transient protection circuit.
- Front and rear tamper detection.
- Mains present LED.
- LED Fault indication.
- Universal mounting means for 3rd party Control Modules.
- Individually fused output(s).
- Deep discharge protection helps prevent battery failure when operating in standby mode for extended periods.

SAFETY



Refer to the Power Supply Equipment (PSE) instruction for safe use.

OPERATING INSTRUCTIONS

This unit is intended for use by trained Service Personnel only. Once installed and operational there are no user functions other than observance of the two LED indicators.

The green Mains LED will be illuminated whilst the mains supply is present. In the event of a fault condition, the lower Fault LED will be illuminated under the conditions shown on page 7.

INSTALLATION AND COMMISSIONING

Installation and repair must be carried out by a certified professional or qualified electrician in accordance with all relevant safety regulations that are applicable.

This unit is only suitable for installation as permanently connected equipment. This PSU is *NOT SUITABLE* for external installation. This unit must be fed from a mains power source having a separate (approved) disconnect device and fitted with a fuse or other over-current protection device rated at 3A maximum. Ensure that the disconnect device used has appropriate earth fault protection to the applicable standard and before installation, ensure that external disconnect device is *OFF*.

EQUIPMENT MUST BE EARTHED.

Medium enclosure: 3 fixing positions

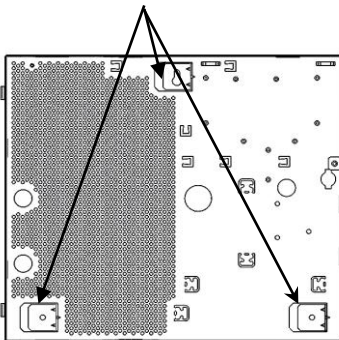

Large enclosure: 5 fixing positions

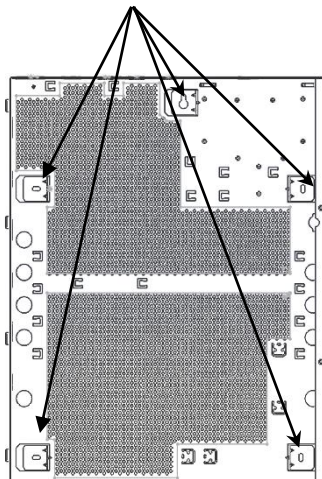

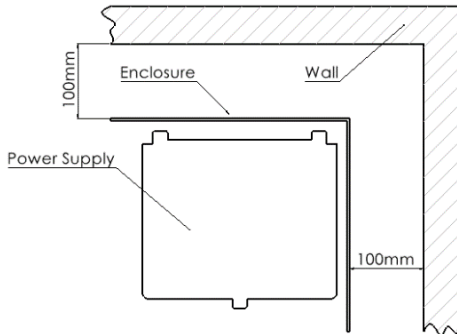

1. Mounting

- Mount enclosure securely in the orientation shown on Page 2 using 5mm diameter x 25mm minimum long screws that are appropriate for the mounting material.
- Allow minimum clearance of 100mm between the enclosure sides and ceilings or adjacent walls. The enclosure must be mounted on a solid and continuous surface (e.g.: a wall, not a column).

2. Cabling

- Route mains and low voltage/signal cables via separate cable entry holes.
- Use bushes and cable glands rated to the required standard.

3. Mains Power Up

- Attach correctly rated mains cable (minimum 0.5mm² [3A], 300/500Vac) and fasten using cable ties.
- In the case of the 12/24Vdc switchable Power Supply, check that the correct output voltage is selected.
- Apply mains power. Check for the correct output voltage on load outputs.
- Check green Main LED is on.
- Disconnect mains power.

4. Load Output

+LOAD	Red +ve voltage O/P to load equipment
-LOAD	Black -ve voltage O/P to load equipment
+BATT	Red lead to standby battery
-BATT	Black lead to standby battery
Tamper x 2	Tamper volt free contact
EPS	Volt free contacts for loss of mains indication
GEN	Volt free contacts for general faults (see signalling outputs)

- Attach correctly rated load cable and fasten using cable ties. Check polarity
- Apply mains power and check green mains LED is on.
NOTE: Fault LED may be lit to indicate that no battery has been connected. This is normal.
- Verify load is operating correctly.
- Disconnect mains power.

5. Standby battery

NOTE: Ensure batteries being fitted to the unit are in good condition.

- Attach supplied battery cables to terminal block and then the battery.
NOTE: Ensure correct polarity of connections: **+ve = red lead**, **-ve = black lead**.
- For 24V systems with two batteries, connect as diagram below.
- Apply mains power and check green Mains LED is on.
- Check the fault indication LED is not illuminated.
- Disconnect mains power. Check that the batteries continue to supply voltage and current to the load. The Green LED should be off.
- NOTE:** Batteries must have sufficient charge to supply the attached load.
- Reconnect mains power. Green LED should be on.
- Disconnect mains power, remove load fuse and check Fault LED is on.
- Replace Load fuse. Reconnect mains power, check Fault LED is off.

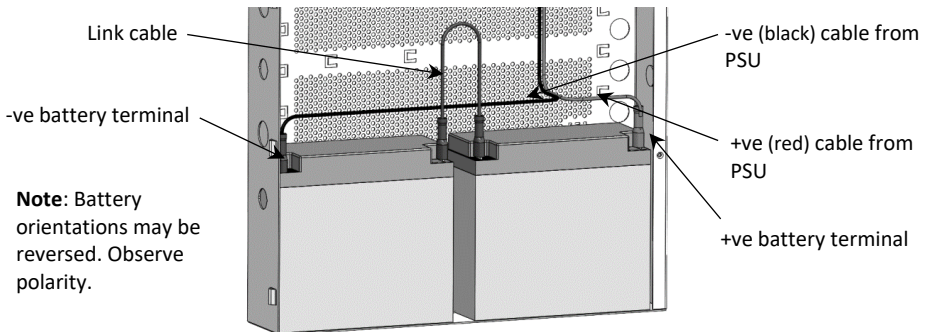

Note: Battery orientations may be reversed. Observe polarity.

6. Tamper

- Connect tamper switch to the inputs of the control and indicating equipment (CIE).
- Close the lid and secure with the screw provided.
- With the unit mounted on the wall, check that the rear tamper is not over a recess or raised area that will adversely affect its operation (e.g., over a mortar course).
- Check that the tamper switch is:
CLOSED when the cover is closed and the lid retaining screws are fitted.
OPEN when the retaining screws are removed.
- Use the adjustment screw if necessary to ensure the tamper switch operates when the lid opens and closes.
- Close and fasten the cover. Re-check the tamper circuit is closed at the control panel.

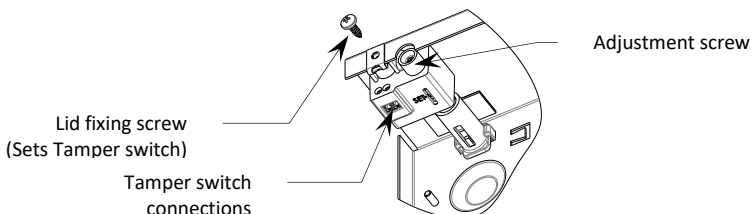

CONNECTIONS, ALL SKUs

+LOAD	Red +ve voltage O/P to load equipment
-LOAD	Black -ve voltage O/P to load equipment
+BATT	Red lead to standby battery
-BATT	Black lead to standby battery
Tamper x 2	Tamper volt free contact
EPS	Volt free contacts for loss of mains indication
GEN	Volt free contacts for general faults (see signalling outputs)

3RD PARTY CONTROLLERS

The hole pattern in the enclosures allows a wide variety of 3rd-party controllers to be mounted in any position. A fixing kit is included that comprises different sizes of standoffs and self-tapping screws for this purpose.

For PCB type controllers, use arrowhead type standoffs:

1. Fit standoffs into suitable PCB mounting holes. Ensure correctly sized standoffs (3mm or 4mm) are selected.
2. Align controller in suitable position in enclosure.
3. Press standoffs into selected hole position.

For controllers that are mounted using screws:

1. Align controller in suitable position in enclosure.
2. Fasten screws (Max torque 0.6Nm.)
Screw types supplied:
No 8 x 3/8" long
M4 x 25mm long Taptite

CONFIGURATIONS

Top Level part numbers for each available configuration are tabled below.
Enclosure: L: Large, M: Medium. See Specification section for dimensions.

SKU	Enclosure	Description
UNIVERSAL-12V-5A-M	M	12V 5A Monitored in Medium enclosure
UNIVERSAL-12V-5A-L	L	12V 5A Monitored in Large enclosure
UNIVERSAL-24V-3A-M	M	24V 3A Monitored in Medium enclosure
UNIVERSAL-24V-5A-L	L	24V 5A Monitored in Large enclosure
UNIVERSAL-1224-L	L	12v 8A / 24V 4A selectable in Large enclosure

SPECIFICATION

Model	UNIVERSAL-12V-5A-x	UNIVERSAL-1224-x (12Vdc)**	UNIVERSAL-24V-3A-x	UNIVERSAL-1224-x (24Vdc)
Input Specification				
Voltage (Rated)	120Vac –240Vac	100Vac – 240Vac		
Voltage (Operating)	90Vac-264Vac			
Frequency	50 – 60 Hz			
Max input current at 90Vac	2A			
Output Specification				
Mains Voltage (Vdc)	13.5V to 14.2V	13.5V to 14.0V	27.0V to 28V nominal dc voltage	
Standby battery Voltage (Vdc)	10V to 12.3V	10V to 12.4V	21.0V to 24.7V	
Ripple (peak to peak Vdc)	<150mV			
Max load current	5A	8A	3A	4A
Fuses				
Mains input fuse	T3.15A HRC			
Output fuse	4 x F1.25A	F8A	4 x F0.8A	F4A
Battery fuse	F5A	N/Applicable	F3.15A	None
PSU protect	N/Applicable	F4A	N/Applicable	F4A

** Default factory setting for the 1224 Power Module is 12Vdc mode

Standby battery		
Battery type	Valve regulated sealed lead acid	
Voltage	12Vdc	24V (12Vdc x 2)
Maximum battery size	Medium enclosure: 2 x 17Ah or 3 x 7 Ah Large enclosure: 2 x 17Ah or 4 x 7Ah	
Battery charge current	Up to 0.5A	
Mechanical	M (Medium) Enclosure	L (Large) Enclosure
Dimensions (Including lid and mounting tabs)	Width: 382mm Height: 337mm Depth: 90mm	Width: 407mm Height: 507mm Depth: 90mm
Weight (Excluding batteries and controllers)	~3.3kg	~5.2kg
Environmental		
Temperature (Operating)	-10°C to 40°C RH75%	
Temperature (Storage)	-20°C to 80°C	

INDICATIONS AND FAULTS

EPS Fault [Mains Fault]	0.1A @ 60Vdc Normally Open volt free contact. Open when loss of mains detected.
GEN Fault [General Fault]	0.1A @ 60Vdc Normally Open volt free contact Open with general fault condition.
TAMP [front and rear] tamper]	Normally Open volt free contact 'Open' when lid opened, or unit removed from wall.
Local Indicators (LEDs)	
Mains Present LED	Green=Mains Present; Off=Mains Missing
Fault LED	Flashing = Fault detected; Off = Operating normally

MAINTENANCE

There is no regular maintenance required of the PSU other than periodic testing and replacement of the standby battery. **Reference should be made to the battery manufacturer's documentation to determine typical/expected battery life with a view to periodic replacement of the battery.**

If the output of the PSU fails, the cause of the failure should be investigated e.g., short circuit load. The fault should be rectified before restoring power to the PSU. If a fuse needs to be replaced, ensure the correct rating and type is used.

END OF LIFE

This product falls within the scope of EU Directives 2012/19/EU Waste Electrical and Electronic Equipment (WEEE) and 2013/56/EU (Battery). At the end of life, the product must be separated from the domestic waste stream and disposed via an appropriate approved WEEE disposal route in accordance with all national and local regulations.

Before disposal of the product, any battery must be removed and disposed of separately via an appropriate approved battery disposal route in accordance with all national and local regulations. Package used batteries safely for onward transport to your supplier, collection point or disposal facility.

See Specification for battery type information.

For more information see: www.recyclethis.info.

The packaging supplied with this product may be recycled.

COMPLIANCE

See [Elmdene International](http://www.elmdene.com) web site for current Declaration of Conformity.

SYMBOLS

Explanation of symbols: (Not all may apply)



Fault Indication



Shock Risk - isolate before attempting access



Mains Present



Do not dispose of in unsorted waste



Protective Earth

Specifications subject to change without notice