



## MST Contact Wiring Guide

Product designed to meet the requirements of EN 50131-2-6:2008 **Grade 2** and Environmental **Class II**. Suitable for use in systems designed to comply with PD6662:2017

### Features

- Surface mounting terminal contact
- Built-in EOL resistors covering multiple control panels
- High reliability cover tamper
- Configurable for Fully Supervised Loop (FSL) and Double Pole wiring
- Single and Multiple door operation
- Screw covers to reduce tampering and improve aesthetics

### EOL Resistor Selection

Use the following table to select the correct Shunt and EOL resistors and corresponding link settings to match the control panel.

Resistors		Links		Control Panel
Shunt	EOL	Shunt	EOL	
1K0	1K0	L8	L4	Honeywell
2K2	2K2	L7	L3	Bosch, Europlex
4K7	4K7	L6	L2	Aritech, HKC
4K7	2K2	L6	L3	ADE, Bosch, Castle, Menvier, Pyronix, Scantronic, Texecom
6K8	4K7	L5	L2	GardTec

\*Default Configuration

Table 1: EOL Resistor and Link Selection

### Installation:

- Step 1: Choose configuration for FSL or double pole and number of doors. See Figs 1 - 4  
 Step 2: Choose and fit FSL resistors links according to Table 1 and Figs 1 - 4

- Figure 1: Fully supervised loop, single leaf door configuration.  
 Figure 2: Fully supervised loop, double leaf door configuration.  
 Figure 3: Standard double pole wiring, single leaf door configuration.  
 Figure 4: Standard double pole wiring, double leaf door configuration.

# FSL/EOL

Figure 1 - **Single Leaf Door Arrangement**  
Shunt Resistor + End Of Line Resistor

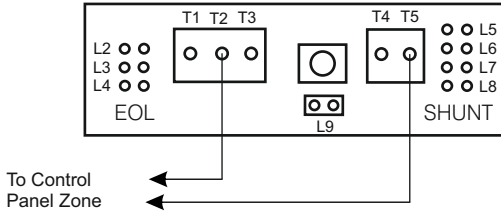

Fit Jumpers - See Page 1, Table 1  
Fit **L9**

Figure 2 - **Double Leaf Door Arrangement**  
Shunt Resistors + End Of Line Resistor

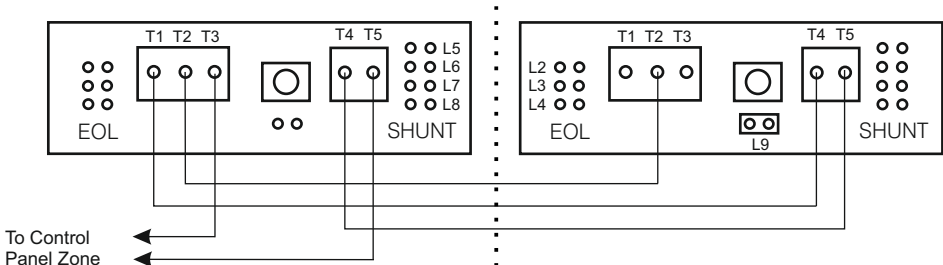

**Sensor 1**

Fit **SHUNT** Jumpers **Only** (See Page 1, Table 1)  
Remove **L9**

**Sensor 2**

Fit **EOL** Jumpers **Only** (See Page 1, Table 1)  
Fit **L9**

# Double Pole

(No Resistors)

Figure 3 - **Single** Leaf Door Arrangement

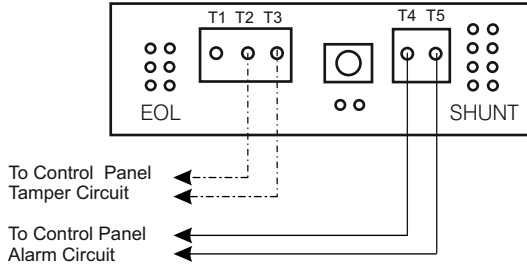

Remove **ALL** Jumpers

Figure 4 - **Double** Leaf Door Arrangement

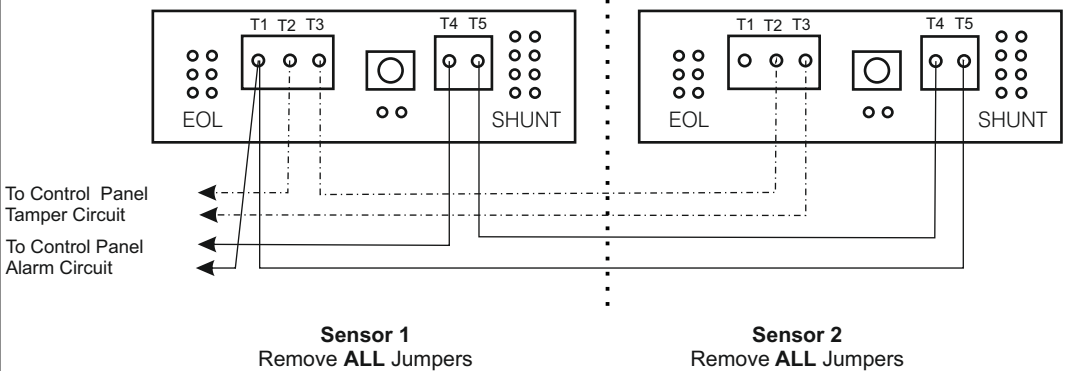

# Specifications

## Contact

Material	Rhodium
Power Handling	10VA
Voltage Rating	100Vdc, 150Vac Max
Current Rating - switch	1.0A Max
Current Rating - carry	1.5A Max
Resistance	<300mohms
Operating Life	>1 x 10 <sup>8</sup> operations

## Housing

Material	Plastic - ABS
Sensor Dimension	82 x 19 x 19mm
Sensor - Fixing Dimensions	69 mm centres
Mounting Screws	M3
IP Rating	IP40
Temperature Range	-10°C to+40°C

## Circuit Diagram

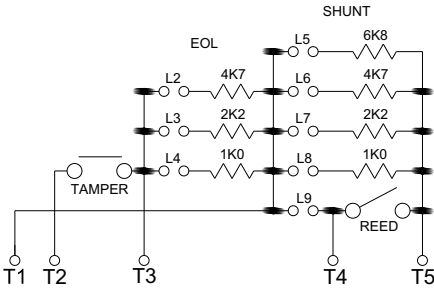

## Terminals & Jumpers

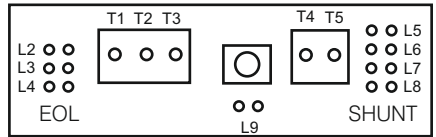

## Lid Attachment

Fit screw covers over fixing screw holes

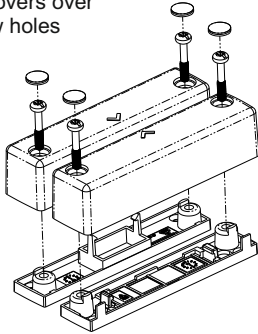

## Fixing Positions

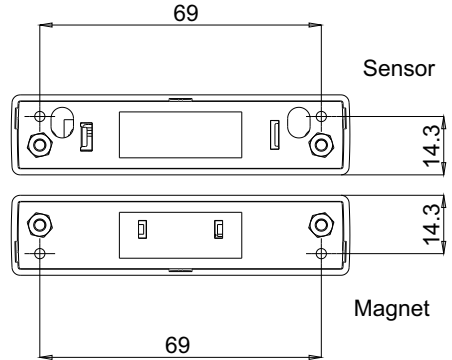

## Operating Distances:

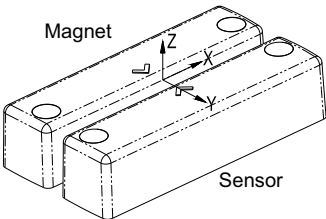

		Switch mounted on Non-Magnetic Surface. (e.g. Wood, PVC, Aluminium)	* Switch mounted on Magnetic Surface. (e.g. Iron, Steel)
Y	Min Close (mm)	32	18
	Max Open (mm)	43	23
+/-X	Min Close (mm)	10	8
	Max Open (mm)	14	11
Z	Min Close (mm)	34	12
	Max Open (mm)	44	16

\*For guidance purposes only